

APPLICATION NOTE – LOGALERT
 USING A VOLT FREE CONTACT FOR DEFROST INPUT

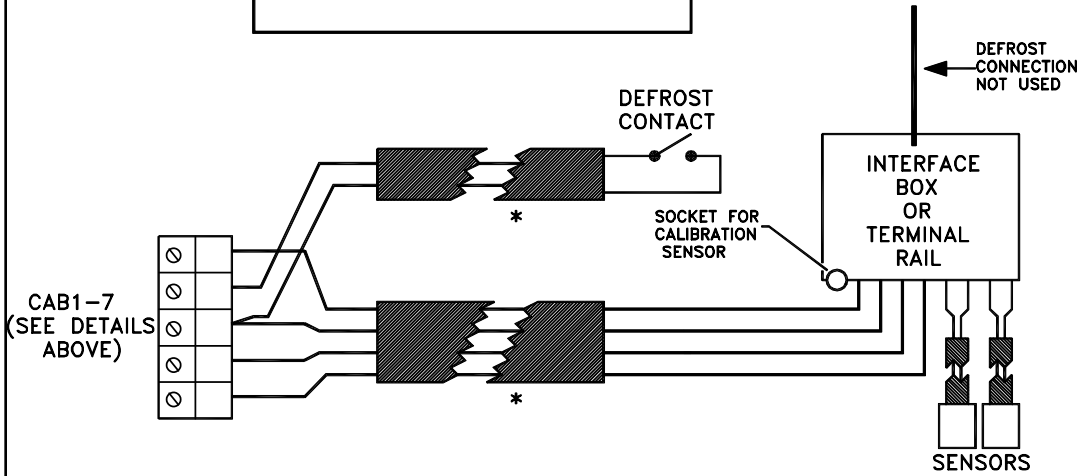

***NOTE:** TO MAINTAIN EMC INTEGRITY MULTICORE MULTISTRAND CABLES MUST BE USED.
 SINGLE CORE & SOLIDCORE CABLES ARE NOT ALLOWED.

ISSUE	DESCRIPTION	APP'D	DATE
1	ORIGINAL ISSUE	MJK	10/95

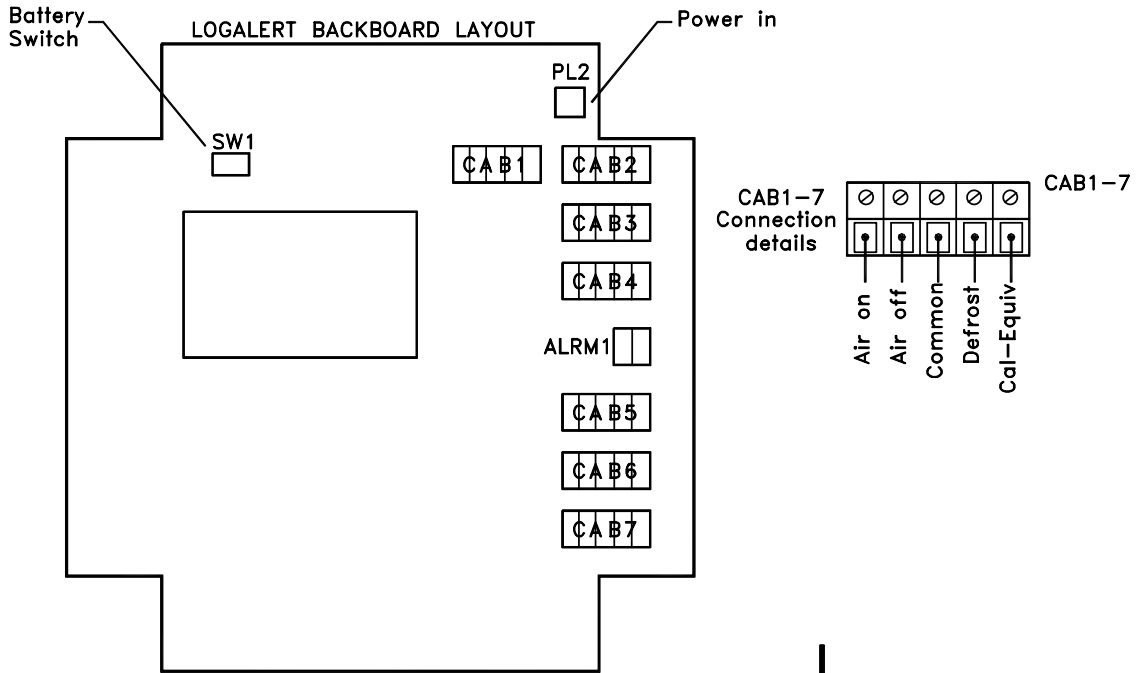

JTL SYSTEMS LTD
 41 KINGFISHER COURT, HAMBRIDGE RD,
 NEWBURY, BERKSHIRE. RG14 5SJ
 TEL: 01635-47585 FAX: 01635 31888

TITLE:
 USING A VOLT FREE CONTACT FOR DEFROST INPUT

TYPE: LOGALERT

PROJ	DRG No	SHT	OF	ISS
	01572	1	1	1