

TYPE LAPI CABINET CONTROLLER

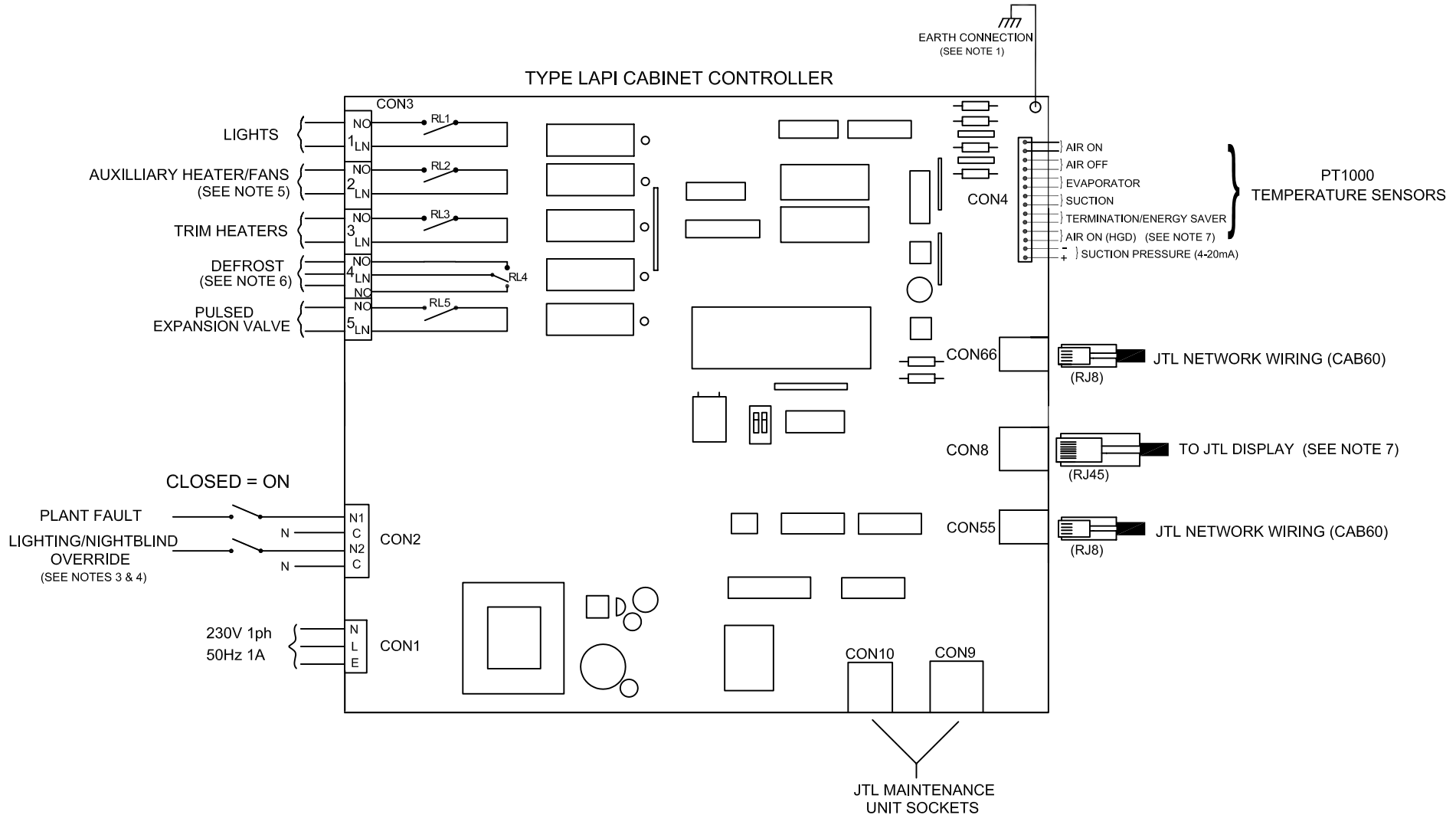

NOTES:

1. THE LAPI CONTROLLER MUST BE EARTHED TO THE CHASSIS VIA THE CONTROLLER FIXING HOLE AS SHOWN.
2. TO MEET EMC REQUIREMENTS THE CONTROLLER MUST BE INSTALLED ACCORDING TO THE INSTALLATION REQUIREMENTS SHEET FOR THIS PRODUCT.
3. INPUTS REQUIRE 'C' CONNECTED TO NEUTRAL AND THE INPUT TO 230Vac WHEN SIGNAL IS PRESENT.
4. PLANT INPUTS TO CON2 MUST BE ON THE SAME PHASE AS THE SUPPLY ON CON1.
THIS UNIT IS NOT RATED FOR 415V
5. FANS/HEATER OUTPUT SELECTABLE USING MAINTENANCE UNIT.
6. THE DEFROST OUTPUT HAS CHANGEOVER CONTACTS. SELECT THE APPROPRIATE OUTPUT FOR THE APPLICATION.
7. FROM FIRMWARE 0.01.1 THE CONTROLLER CAN CONTROL/MONITOR SINGLE EVAPORATOR WELL AND HGD CABINETS. IT CAN DISPLAY 2 TEMPERATURES WHEN USED IN CONJUNCTION WITH A CONVD12 DISPLAY SPLITTER.

THIS IS AN UNCONTROLLED COPY - UNLESS STAMPED WITH CONTROLLED COPY STAMP

JTL SYSTEMS LTD		41 KINGFISHER COURT, HAMBRIDGE RD, NEWBURY BERKSHIRE: RG14 5SJ TEL: 01635 263646 FAX: 01635 263647	
ISS	DESCRIPTION	APP'D	DATE
2	HGD FUNCTIONS ADDED	MJK	09/09
1	ORIGINAL ISSUE	MJK	01/08
TITLE: CABINET CONTROLLER CONNECTIONS			
TYPE: LAPI			
PROJ.	DRG No:	SHT	OF
LA	03408	1	1
			ISS.
			2