

Electrical installation requirements

Care should be taken to separate the power and signal cables to prevent electrical interference and possible damage due to inadvertent connection.

The power outputs are fitted with suppressors to protect against electrical interference when switching off solenoid valves or contactors. It is therefore essential to observe the output polarity. The line voltage should be connected to the terminals marked **LN** and the switched loads to **NO** or **NC**.

The plant inputs are electrically isolated. A line voltage should be connected for the logical conditions **lighting override** and **defrost on**. The terminals marked **C** should be connected to the supply voltage neutral.

CE Conformance

This unit conforms with the relevant EU standards when installed according to the JTL Installation Requirements for this product.

Use of Maintenance unit

The controller can be checked and the operation adjusted using a JTL portable maintenance unit which plugs into the controller. Each item of information has an item number. The more important items are listed in the tables overleaf. Examples:

To read item 21 press: **ITEM** **2** **1** **ENTER**

To set item 30 to -20.0 press:

ITEM **3** **0** **ENTER** **SET** **-** **2** **0** **0** **ENTER**

To correct errors press: **CANCEL**

To select next or previous items press: **+** and **-**

Initial commissioning and bitswitch settings

The controller has 4 sets of data built in to its program for use during commissioning. These can be accessed by setting the bitswitches as shown in the table overleaf and then setting item 9 to 1. This loads into the controller a suitable set of data for the selected type of case. Adjustments should then be made as necessary. The range over which the settings can be adjusted is also defined by the bitswitch setting.

If a JTL communications network is connected to the controller then the unit number should be set on item 1.

Temperature display

The temperature displayed is computed from the air on and air off temperatures. A factor is used to proportion the air off and air on temperatures.

Control strategy

The air off temperature is controlled to a computed setpoint shown on item 28. If the temperature falls below this setpoint the liquid valve is closed. There is a deadband of ± 0.2 °C.

The computed air off temperature setpoint is calculated by comparing the displayed temperature with the cabinet temperature setpoint. The computed setpoint is raised or lowered depending on whether the cabinet temperature is below or above the cabinet temperature setpoint. The computed air off setpoint cannot go below the value set on item 31.

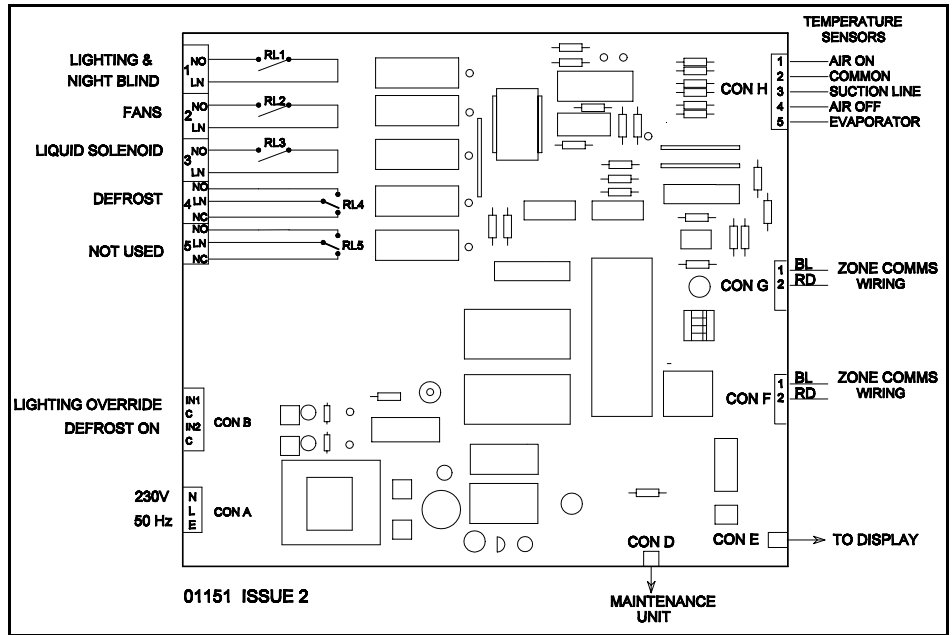

High temperature alarms are cancelled during defrost and defrost recovery.

Defrost

The defrost sequence can be initiated in 3 ways. These can be by deduction from the suction temperature, by command on the JTL communications network, or by contact input.

There is a choice of 2 methods of defrost operation, termination or control, using item 75. In termination mode the defrost output relay is energised during defrost recovery period and at any time when the termination temperature is exceeded. In control mode the defrost output relay is energised during the defrost period.

The liquid solenoid is left open during suction initiated defrost and closed during network initiated defrost. The auxiliary output can be selected for fan or heater control. During defrost the fans can be stopped or the auxiliary heater energised.

The display shows "dEF " NOTE: No defrost can be detected within 3 hours of the previous defrost.

Defrost recovery

When the termination temperature or time is reached the controller enters defrost recovery. The heater is de-energised.

For network and contact initiated defrost a time delay can be applied (item 49) after defrost before the liquid valve is reopened.

During defrost recovery the fans can be controlled depending on the evaporator temperature. When the evaporator temperature is low enough, the fans start. There is a 5 degree deadband.

The display shows "dEFr".

Lighting and Night Blind Control

The cabinet lights and night blinds can be sequenced on and off by command from the JTL network. An override switch input facility is provided which raises the blinds and turns the lights on.

Alarms

The cabinet and air off temperatures are monitored continually. The temperatures are averaged over the period set on item 47. If either of the average temperatures exceeds the alarm level then an alarm is given which is shown on the display and available, for remote indication, on the JTL alarm system.

ADJUSTABLE PARAMETERS				Bitswitch settings
Item	Function	Range	Units	
1	Unit number	0.1 to 899.9		4321
30	Cabinet temperature setpoint	-30 to +10	°C	xxCC Frozen food
31	Air off temperature setpoint	-39 to +5	°C	xxCO Ice cream
32	Overtemperature tolerance	0 to +20	°C	xxOC Chillers
33	Cabinet temperature factor	20 to 80		xxOO Produce
36-39	Probe selections	0=off 1=on		
45	Suction or comms initiated	0=comms 1=suction		where
47	Alarm averaging time	00:30 to 03:00	hr:mn	
48	Compressor starts/hour	unlimited /10/15/20		C = closed
49	Refrigeration delay after defrost	00:00 to 00:10	hr:mn	O = open
50	Defrost termination temp (air off 2)	0 to +20	°C	x = don't care
57	Defrost termination time	00:05 to 01:00	hr:mn	
58	Defrost initiation temp (suction 2)	-5 to +20	°C	closed = dot visible
69	Number of defrosts expected	0 to 6		
75	Defrost control mode	0=termination 1=control		
102	Probe selection	0=Tempkey 1=CDK		
104	Auxiliary output selection	0=off 1=Fan 2=Heater		
110	Lighting control selection	0=off 1=on		
118	Lighting contractor selection	0=n.o 1=n.c		

OTHER USEFUL ITEMS			
Item	Function	Item	Function
20	Cabinet temperature	71	Defrost input state
21	Air on temperature	72	Defrost output state
22	Air off temperature	73	Liquid valve output state
23	Evaporator temperature	74	Auxiliary output state
24	Suction line temperature	77	Forced defrost
25	Superheat	78	Inhibit defrost
28	Effective air off setpoint	79	Forced refrigeration
40	Duration of last defrost	111	Communications lighting command
41	Time since end of last defrost	112	Lighting override input state
42	Duration of this defrost	113	Lighting output state
46	Communications defrost command	114	Force lights on
70	Operating mode	115	Force lights off

Full operating manuals and item number information can be obtained from your supplier or JTL Systems.



This unit conforms with the relevant EU standards when fitted in accordance with its installation instructions.

Applicable Documentation

Item Numbers	Doc No. 01128
Software Variations	Doc No. 01249
Wiring Diagrams	Doc No. 00942, 01373
Evaporator Manual	Doc No. 01923
Installation Requirements	Doc No. 01662
Outline Details	Doc No. n/a

LCNBuserguide.wpd Issue 3 Mar 1997 Doc No 01386

www.jtl.co.uk

JTL Systems Ltd . 41 Kingfisher Court . Hambridge Road . Newbury . Berks . RG14 5SJ Tel: (01635) 263646 Fax: (01635) 263647

JTL SERVICE CENTRE HELP DESK: 0870 321 HELP (4357)