

Electrical Installation Requirements

Care should be taken to separate the power and signal cables to prevent electrical interference and possible damage due to inadvertent connection.

The power outputs are fitted with suppressors to protect against electrical interference when switching off solenoid valves or contactors. It is therefore essential to observe the output polarity. The line voltage should be connected to the terminals marked **LN** and the switched loads to **NO** or **NC**.

The plant inputs are electrically isolated. A line voltage should be connected for the logical conditions **lighting override** and **defrost on**. The terminals marked **C** should be connected to the supply voltage neutral.

CE Conformance

This unit conforms with the relevant EU standards when installed according to the JTL Installation Requirements for this product.

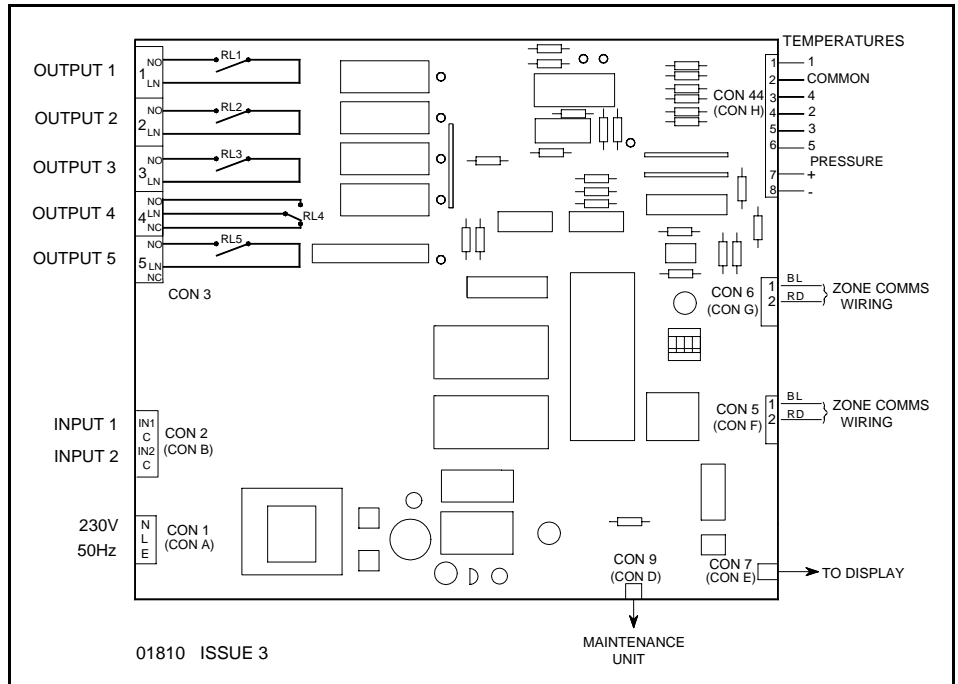

Inputs

Input (Connector B)			
IN1 C	INPUT 1	(LINE) (NEUTRAL)	LIGHTING OVERRIDE
IN2 C	INPUT 2	(LINE) (NEUTRAL)	DEFROST ON
Temperatures and Pressure (Connector H)			
1	TEMP 1		AIR ON (WELL)
2	COMMON		
3	TEMP 4		SUCTION LINE
4	TEMP 2		AIR OFF
5	TEMP 3		EVAPORATOR
6	TEMP 5		AIR ON (HGD)
7	PRESSURE +		SUCTION LINE
8	PRESSURE -		

Outputs

Outputs (Connector C)			
1 NO 1 LN	OUTPUT 1	(N/O LOAD) (LINE)	LIGHTING & BLINDS CONTACTOR
2 NO 2 LN	OUTPUT 2	(N/O LOAD) (LINE)	FANS
3 NO 3 LN	OUTPUT 3	(N/O LOAD) (LINE)	LIQUID SOLENOID VALVE
4 NO 4 LN 4 NC	OUTPUT 4	(N/O LOAD) (LINE) (N/C LOAD)	DEFROST
5 NO 5 LN	OUTPUT 5	(N/O LOAD) (LINE)	PULSED EXPANSION VALVE
5 NC	NOT USED		

Use of Maintenance Unit

The controller can be checked and the operation adjusted using a JTL portable maintenance unit which plugs into the controller. Each item of information has an item number. The more important items are listed in the tables overleaf.

Examples:

To read item 21 press: **ITEM** **2** **1** **ENTER**

To set item 30 to -20.0 press:

ITEM **3** **0** **ENTER** **SET** **-** **2** **0** **0** **ENTER**

To correct errors press: **CANCEL**

To select next or previous items press: **+** and **-**

Initial Commissioning and Bitswitch Settings

The controller has 2 sets of data built in to its program for use during commissioning. These can be accessed by setting the bitswitches as shown in the table overleaf and then setting item 9 to 1. This loads into the controller a suitable set of data for the selected type of case. Adjustments should then be made as necessary. The range over which the settings can be adjusted is also defined by the bitswitch setting.

If a JTL communications network is connected to the controller then the unit number should be set on item 1.

Temperature Display

The LCIL drives 2 displays, one for the well case and one for the half glass door case. This requires the use of a display splitter type CONVD4 and a cable type CAB08. The temperatures displayed are computed from the air on and air off temperatures. A factor is used to proportion the air off and air on temperatures.

The CONVD4 display splitter will drive the following JTL displays when used with the extension cables shown in the table.

Display	Cable
LCD1	-
LCD2	CAB4
LCD5	CAB4

The cables are available in various lengths.

Control Strategy

The LCIL controller is specifically designed to control the Linde ATR combined half glass door and well case with a single evaporator.

The air off temperature is controlled to a computed setpoint shown on item 28, by controlling either a pulsed expansion valve or liquid line solenoid valve with a mechanical expansion valve. The choice is selected on item 160.

The computed air off temperature setpoint is calculated by comparing the 2 displayed temperatures with the cabinet temperature setpoints. The computed setpoint is raised or lowered depending on whether the cabinet temperature, on the worst of the 2 cabinets, is below or above the cabinet temperature setpoint. The computed air off setpoint cannot go below the value set on item 31.

For liquid solenoid control, if the air off temperature falls below the computed setpoint the liquid valve is closed. There is a deadband of ± 0.2 °C.

For pulsed expansion valve control, the valve opening is controlled primarily using a PI strategy on the air off temperature. The valve is opened and shut over a fixed period of time (normally 6.25 s) to meter the appropriate amount of refrigeration. The proportional gain and the integral time constant for the PI control are adjustable.

On PEV control, if the superheat falls below the minimum level set on item 162, the PEV is progressively shut to effect recovery from excess liquid supply. This is called override.

After override is complete, ie. superheat recovers, PI control will be resumed but with a modified (reduced) value. The modifier is shown on item 190 and the output to the PEV valve is shown on item 168.

The superheat is calculated using the suction pressure and temperature.

Defrost Strategies

The defrost strategy can be initiated in 4 ways using item 107. Defrost initiation can be by real time clock, by deduction from the suction temperature, by command on the JTL communications network, or by contact input.

There is a choice of 2 methods of defrost operation, termination or control, using item 75. In termination mode the defrost output relay is energised during defrost recovery period and at any time when the termination temperature is exceeded. In control mode the defrost output relay is energised during the defrost period.

The liquid solenoid or PEV is closed during all forms of defrost. The auxiliary output can be selected for fan or heater control. During defrost the fans can be stopped.

For network, real time and contact initiated defrost, a pump down delay can be applied (item 61) before the defrost/output and heater are energised. During pump down the liquid outputs are deenergised.

For network initiated defrost, a defrost learning strategy is included. The last 24 hours defrost operation is continuously monitored and the defrost schedule is learned. If network communication fails, the selected backup strategy is automatically used. The unit reverts to network control whenever the network communications is operational.

The display shows "dEF "

NOTE: No suction initiated defrost can be detected within 3 hours of the previous defrost.

Defrost Recovery

When the termination temperature or time is reached the controller enters defrost recovery. The heater is de-energised. The termination temperature can be chosen using item 35.

For network, real time and contact initiated defrost a time delay can be applied (item 49) after defrost before the liquid valve is reopened.

A drain down time delay can be applied (item 59) after defrost before the liquid valve is reopened.

During defrost recovery the fans can be controlled depending on the evaporator temperature.

Forced Refrigeration and Defrost

The maintenance unit can be used to force controller into a particular mode. This is done using items 77-79. While the maintenance unit is plugged in the controller will remain in the selected mode permanently. Once the maintenance unit is unplugged the controller will revert to normal control after 30 minutes.

When the network initiated defrost strategy is selected, forced defrost will send a command to the JTL defrost scheduler to initiate a defrost and does not act locally. NOTE this feature was introduced in Apr 2000 and requires the JTL defrost scheduler and JTL network controller to support this function.

Lighting and Night Blind Control

The cabinet lights and night blinds can be sequenced on and off by command from the JTL network. An override switch input facility is provided which raises the blinds and turns the lights on.

Alarms

The cabinet and air off temperatures are monitored continually. The temperatures are averaged over the period set on item 47. If either of the average temperatures exceeds the alarm level then an alarm is given which is shown on the display and available, for remote indication, on the JTL alarm system. High temperature alarms are cancelled during defrost and defrost recovery.

The cabinet and air off temperature tolerance is set on item 32.

Excessive Superheat Alarms (PEV control only)

If the measured Superheat exceeds 50°C then a sensor fault is assumed and the maximum opening of the expansion valve is reduced to 50% of the maximum allowed. When the measured Superheat is between 30 and 50°C the fault condition is activated if the suction temperature exceeds the air on temperature.

Network Shutdown and Fans Only Mode

This controller supports the JTL Network shutdown and fans only facilities. When these facilities are enabled. If a shutdown or fans only command is received over the JTL Network, the refrigeration is stopped and alarms are disabled. The high temperature alarm sequence is initialised.

ADJUSTABLE PARAMETERS				LCIL
Item	Function	Range	Units	Bitswitch settings
1	Unit number	0.1 to 899.9		4321
30	Cabinet temperature setpoint	-30 to +10	°C	xxCC Frozen food
31	Air off temperature setpoint	-39 to +5	°C	xxCO Ice cream
32	Cabinet overtemperature tolerance	0 to +20	°C	xxOC Chillers
33	Cabinet temperature factor	20 to 80	°C	xxOO Produce
35	Termination temperature selection	0=Air off 1=evap		
47	Alarm averaging time	00:30 to 03:00	hr:mn	where
48	Compressor starts/hour	unlimited /10/15/20		C = closed
49	Refrigeration delay after defrost	00:00 to 00:10	hr:mn	O = open
50	Defrost termination temp (air off)	0 to +20	°C	x = don't care
51-56	Defrost schedule	00:01 - 23:59	hr:mn	
57	Defrost termination time	00:05 to 01:00	hr:mn	closed = dot visible
58	Defrost initiation temp (suction)	-5 to +20	°C	
59	Drain down time	00:00 - 00:10	hr:mn	
60	Defrost schedule 12/24 hour clock	0=24hr 1=12hr		
61	Pump down time	00:00 - 00:10	hr:mn	
62	Network shutdown and fans only commands	0=disabled 1=enabled		
65	Invert defrost input	0=no 1=yes		
69	Number of defrosts expected	0 to 12		
75	Defrost control mode	0=termination 1=control		
107	Defrost strategy	0=none 1=Suction 2=Network 3=Time 4=Contact		
110	Lighting control selection	0=off 1=on		
118	Lighting contactor selection	0=n.o 1=n.c		
133	Enable plant to override temp control	0=disabled 1=enabled		
134	Enable plant to cut off refrigeration	0=disabled 1=enabled 3=Time		
136	Defrost termination method	1=Evaporator 2=Air off 3=Termination 4=Time only		
205-209	Temperature sensor selections	0=off 1=on		
PULSED EXPANSION VALVE FUNCTIONS				
157	Refrigerant type	0 - 6 (R type shown on MU display)		
158	Pressure transducers zero offset	-7 to +7	psi	
160	Control valve	0=Liquid solenoid 1=PEV		
161	Control strategy	1=2 temperature 2=pressure		
162	Minimum superheat (pressure)	0 - 10	°C	
163	Maximum valve opening (pressure)	10 - 100	%	
164	Minimum valve opening	0 -50	%	
170	PEV proportional gain	1 - 100		
171	PEV integral time constant	1 - 250		
174	High suction pressure shutdown	0=disabled 1=enabled		
177	Auto zero pressure enable	0=disabled 1=enabled		
179	Pressure display choice	1=psi 2=bar 3=kPa		

OTHER USEFUL ITEMS			
Item	Function	Item	Function
20	Cabinet temperature	71	Defrost input state
21	Air on temperature (well case)	72	Defrost output state
22	Air off temperature	73	Liquid valve output state
23	Evaporator temperature	74	Auxiliary output state
24	Suction line temperature	77	Forced defrost
25	Air on temperature (hgd case)	78	Inhibit defrost
28	Effective air off setpoint	79	Forced refrigeration
40	Duration of last defrost	111	Communications lighting command
41	Time since end of last defrost	112	Lighting override input state
42	Duration of this defrost	113	Lighting output state
46	Network defrost command	114	Force lights on
63	Network shutdown and fans only command states	115	Force lights off
70	Operating mode		
PULSED EXPANSION VALVE FUNCTIONS			
154	Force pressure average to current reading	168	PEV valve opening (%)
155	Suction pressure	169	PEV status
156	Superheat	181	Time since last override (hr:mn)
159	Auto zero offset	182	Duration of last override (sec)
166	Force PEV opening (%)	190	Modifier output (%)

OUTPUT STATE DIAGRAM FOR JTL CONTROLLER					LCIL
MODE OF OPERATION	OUTPUT & FUNCTION (See note 5)				
	RL2	RL3	RL4		RL5
	FANS (N/O) can be set to run always [108]	LIQUID SOLENOID VALVE (N/O) See Note 1	DEFROST (C/O)		ELECTRONIC EXPANSION VALVE (N/O) Solid state output See Note 1
			ITEM 75		
		CONTROL	TERMINATION		
REFRIGERATION	ON (See note 4)	CYCLES ON AIR OFF TEMPERATURE	OFF	ON ABOVE TERMINATION TEMP	CYCLES ON AIR OFF TEMPERATURE
PUMP DOWN Adjustable time [61]	OFF	OFF	OFF (from version 0.01.0)	OFF	OFF
DEFROST Time/temp terminated [57]/[50]	OFF	OFF	CYCLES ON TERMINATION TEMP (from version 0.01.3)	OFF	OFF
DRAIN DOWN Adjustable time [49]	OFF	OFF	OFF	ON	OFF
LIQUID HOLD OFF Adjustable time [49]	OFF	OFF	OFF	ON	OFF
RECOVERY TIME Time/temp terminated	TEMPERATURE OR TIME CONTROLLED (See Note 6)	CYCLES ON AIR OFF TEMPERATURE	OFF	ON	CYCLES ON AIR OFF TEMPERATURE
REFRIGERATION	ON (See note 4)	CYCLES ON AIR OFF TEMPERATURE	OFF	ON ABOVE TERMINATION TEMP	CYCLES ON AIR OFF TEMPERATURE
PLANT FAULT	OFF	OFF	OFF	ON	OFF
UNIT SHUTDOWN	ON	OFF	OFF	OFF	OFF
FORCED DEFROST	ON	OFF	ON	OFF	OFF
FORCED REFRIGERATION	ON	ON	OFF	ON	CYCLES ON AIR OFF TEMPERATURE
INHIBIT DEFROST	ON	CYCLES ON AIR OFF TEMPERATURE	OFF	ON	CYCLES ON AIR OFF TEMPERATURE

NOTE 1: EITHER RL3 OR RL5 IS OPERATED DEPENDING ON SETTING [160]

NOTE 3: INN1 REPRESENTS ITEM NN ON THE JTL MAINTENANCE UNIT

NOTE 5: RL1 IS FOR LIGHTING CONTROL

NOTE 4: CAN CYCLE ON ENERGY SAVING TEMPERATURE (SELECTED BY ITEM 130)

NOTE 6: FANS OFF UNTIL TIME SET ON ITEM 109 REACHED. IF 109 SET TO 00:00 FANS CYCLE ON EVAPORATOR TEMPERATURE.

Relay Output Rating

RL1-4 5A resistive.

RL5 2A resistive

Supply Requirements

230 V ac 48-62 Hz Supply 6 VA maximum inputs 2 mA maximum



This unit conforms with the relevant EU standards when fitted in accordance with its installation instructions.

Note

The information contained in this document applies to the current version of the unit supplied with it. Full operating manuals, item number and software variation information can be obtained from your supplier or JTL Systems.

Applicable Documentation

Item Numbers Software Variations
Doc No. 01925 Doc No. 01926

Wiring Diagrams Evaporator Manual Installation Requirements
Doc No. 01990 Doc No. 01923 Doc No. 01662
Doc No. 01992
Doc No. 02298

01932-LCIL.wpd Issue 2 May 2000 Doc No. 01932

www.jtl.co.uk

JTL Systems Ltd . 41 Kingfisher Court . Hambridge Road . Newbury . Berks . RG14 5SJ Tel: (01635) 263646 Fax: (01635) 263647

JTL SERVICE CENTRE HELP DESK: 0870 321 HELP (4357)