

**Electrical Installation Requirements**

Care should be taken to separate the power and signal cables to prevent electrical interference and possible damage due to inadvertent connection.

The power outputs are fitted with suppressors to protect against electrical interference when switching off solenoid valves or contactors. It is therefore essential to observe the output polarity. The line voltage should be connected to the terminals marked **LN** and the switched loads to **NO** or **NC**.

The plant inputs are electrically isolated. A line voltage should be connected for the logical conditions **lighting override** and **defrost on**. The terminals marked **C** should be connected to the supply voltage neutral.

**CE Conformance**

This unit conforms with the relevant EU standards when installed according to the JTL Installation Requirements for this product.

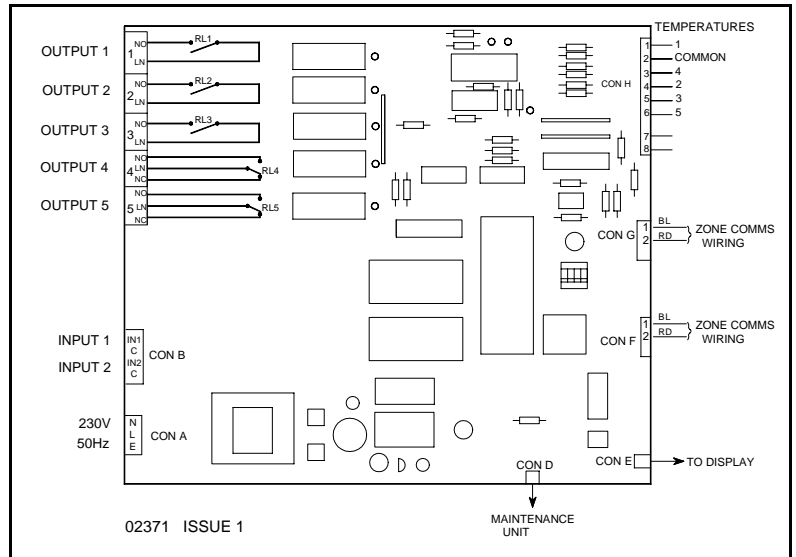

**Inputs**

Input (Connector B)			
IN1 C	INPUT 1	(LINE) (NEUTRAL)	DEFROST ON
IN2 C	INPUT 2	(LINE) (NEUTRAL)	LIGHTING OVERRIDE
Temperatures and Pressure (Connector H)			
1	TEMP 1		AIR ON
2	COMMON		
3	TEMP 4		SUCTION LINE
4	TEMP 2		AIR OFF
5	TEMP 3		EVAPORATOR
6	TEMP 5	ENERGY SAVING OR	TERMINATION
7	NOT USED		
8	NOT USED		

**Outputs**

Outputs (Connector C)			
1 NO 1 LN	OUTPUT 1	(N/O LOAD) (LINE)	LIGHTING & BLINDS CONTACTOR
2 NO 2 LN	OUTPUT 2	(N/O LOAD) (LINE)	FANS / HEATERS
3 NO 3 LN	OUTPUT 3	(N/O LOAD) (LINE)	TRIM HEATER
4 NO 4 LN 4 NC	OUTPUT 4	(N/O LOAD) (LINE) (N/C LOAD)	DEFROST
5 NO 5 LN 5 NC	OUTPUT 5	(N/O LOAD) (LINE) (N/C LOAD)	LIQUID SOLENOID VALVE

**Use of Maintenance Unit**

The controller can be checked and the operation adjusted using a JTL portable maintenance unit which plugs into the controller. Each item of information has an item number. The more important items are listed in the tables overleaf.

Examples:

To read item 21 press: **ITEM** **2** **1** **ENTER**

To set item 30 to -20.0 press:

**ITEM** **3** **0** **ENTER** **SET** **-** **2** **0** **0** **ENTER**

To correct errors press: **CANCEL**

To select next or previous items press: **+** and **-**

**Initial Commissioning and Bitswitch Settings**

The controller has 4 sets of data built in to its program for use during commissioning. These can be accessed by setting the bitswitches as shown in the table overleaf and then setting item 9 to 1234. This loads into the controller a suitable set of data for the selected type of case. Adjustments should then be made as necessary. The range over which the settings can be adjusted is also defined by the bitswitch setting.

If a JTL communications network is connected to the controller then the unit number should be set on item 1.

**Temperature Display**

The temperature displayed is computed from the air on and air off temperatures. A factor is used to proportion the air off and air on temperatures.

The temperature can be displayed in Celsius or Fahrenheit as selected by item 122.

The LCPT controller will drive the following JTL displays when used with the extension cables shown in the table. The LCD6, LCD7 and LCD9 displays incorporate a keyswitch. This switch can be used to select various functions as described below. A maximum of 2 additional functions can be selected. On LCD6 and LCD9 if only one additional function is selected, then it is available in either of the extra 2 positions.

Display	Cable	Switch	Item 129
LCD1	CAB40	None	LCD1 (2)
LCD5	CAB44	None	LCD1 (2)
LCD6	CAB34	3 position	LCD1 (2)
LCD7	CAB34	2 position	LCD1 (2)
LCD8	CAB51	None	LCD8 (3)
LCD9	CAB51	3 position	LCD8 (3)

The cables are available in various lengths.

### Control Strategy

The air off temperature is controlled to a computed setpoint shown on item 28, by controlling a liquid line solenoid valve with a mechanical expansion valve.

The computed air off temperature setpoint is calculated by comparing the displayed temperature with the cabinet temperature setpoint. The computed setpoint is raised or lowered depending on whether the cabinet temperature is below or above the cabinet temperature setpoint. The computed air off setpoint cannot go below the value set on item 31.

The LCPT controller can be set to operate from 2 cabinet temperature setpoints by setting item 123. The setpoint to be used is then selected using the display keyswitch. The setpoints are set on items 124 and 125 and the current setpoint is displayed on item 30.

For liquid solenoid control, if the air off temperature falls below the computed setpoint the liquid valve is closed. There is an adjustable deadband set using item 140.

### Defrost Strategies

The defrost strategy can be initiated in 4 ways using item 107. Defrost initiation can be by real time clock, by deduction from the suction temperature, by command on the JTL communications network, or by contact input.

There is a choice of 2 methods of defrost operation, termination or control, using item 75. In termination mode the defrost output relay is energised during defrost recovery period and at any time when the termination temperature is exceeded. In control mode the defrost output relay is energised during the defrost period.

The liquid solenoid is closed during all forms of defrost. The auxiliary output can be selected for fan or heater control. During defrost the fans can be stopped or the auxiliary heater energised.

For network, real time and contact initiated defrost a pump down delay can be applied (item 61) before the defrost/output and heater are energised. During pump down the liquid outputs are deenergised.

For network initiated defrost, 2 defrost backup strategies are included. The strategy choice is made on item 107. For learned backup the last 24 hours defrost operation is continuously monitored and the defrost schedule is learned. For real time backup the defrost schedule as set up for real time defrost on items 51-56 is used. If network communication fails, the selected backup strategy is automatically used. The unit reverts to network control whenever the network communications is operational.

The backup strategy is also invoked if the network signals that communications has failed to the defrost scheduler.

The controller stays in defrost at least until the minimum defrost time, on item 145, is exceeded. If the termination temperature is reached before the minimum defrost time then the defrost heater is cycled.

The display shows "dEF "

**NOTE:** No suction initiated defrost can be detected within 3 hours of the previous defrost.

### Defrost Recovery

When the termination temperature or time is reached the controller enters defrost recovery. The heater is de-energised. The termination method can be chosen using item 144.

For network, real time and contact initiated defrost a time delay can be applied (item 49) after defrost before the liquid valve is reopened.

A drain down time delay can be applied (item 59) after defrost before the liquid valve is reopened. During drain down if the auxiliary heater output is selected it is energised.

During defrost recovery the fans can be controlled depending on the evaporator temperature or time delay after defrost. If item 109 is set to 00:00. When the evaporator temperature is low enough, the fans start. There is a 5 degree deadband. The display shows "dEFr". If the item 109 is set to a time then the fans are held off until the time delay has occurred.

### Forced Refrigeration and Defrost

The maintenance unit can be used to force controller into a particular mode. This is done using items 77-79. While the maintenance unit is plugged in the controller will remain in the selected mode permanently. Once the maintenance unit is unplugged the controller will revert to normal control after 30 minutes.

When the network initiated defrost strategy is selected, forced defrost will send a command to the JTL defrost scheduler to initiate a defrost and does not act locally.

### Lighting and Night Blind Control

The cabinet lights and night blinds can be sequenced on and off by command from the JTL network. An override switch input facility is provided which raises the blinds and turns the lights on. The lights can be switched off from the display keyswitch if item 119 is set to 1 (enabled). The lights are switched off if either fans only or shutdown are selected.

### Energy Saving - Fan Control

If energy saving is selected using item 130, then the fans will be cycled during normal refrigeration. When the energy saving temperature, item 131, goes below the energy saving setpoint, item 132, the fans stop. There is a deadband of  $\pm 0.5^{\circ}\text{C}$

### High Temperature Alarms

The cabinet and air off temperatures are monitored continually. The temperatures are averaged over the period set on item 47. If either of the average temperatures exceeds the alarm level then an alarm is given which is shown on the display and available, for remote indication, on the JTL alarm system. High temperature alarms are cancelled during defrost and defrost recovery.

The cabinet temperature tolerance is set on item 32 and the air off tolerance on item 34. Setting either of these tolerances to  $0.0^{\circ}\text{C}$  disables the relevant alarm.

### Network Shutdown and Fans Only Mode

This controller supports the JTL Network shutdown and fans only facilities. When these facilities are enabled by item 62. If a shutdown or fans only command is received over the JTL Network, the refrigeration is stopped and alarms are disabled. The high temperature alarm sequence is initialised.

### Display Controlled Shutdown

The controller can be shutdown for servicing purposes using the display switch. This feature is enabled by item 138.

### Display Controlled Fans Only Mode

The controller can be put into fans only mode using the display switch. This feature is enabled by item 136.

### Suction Pressure Optimisation

When used in conjunction with JTL pack control and suction optimisers this unit is normally included in the suction pressure optimiser algorithm. It can be explicitly excluded when both air sensors are faulty by setting item 200 to 1.

### Daylight Saving

When connected to a JTL network this controller can operate by displaying daylight saving time for its time and defrost schedule. Daylight saving operation is selected by setting item 18. The connected network controller then adjusts the times automatically during the daylight saving period.

### Temperature Sensor Type

The type of sensor used can be adjusted using item 102. The standard characteristics used in 5000 ohms @  $25^{\circ}\text{C}$ . This controller also supports the Elm sensor characteristics of 2000 ohms @  $25^{\circ}\text{C}$ .

ADJUSTABLE PARAMETERS				LCPT
Item	Function	Range	Units	Bitswitch settings
1	Unit number	0.1 to 899.9		4321
18	Daylight saving operation	0=standard time 1=daylight saving time		xxCC Frozen food
31	Air off temperature setpoint	-39 to +5	°C	xxCO Ice cream
32	Cabinet overtemperature tolerance	0 to +20	°C	xxOC Chillers
33	Cabinet temperature factor	20 to 80		xxOO Produce
34	Air off over temperature tolerance	0 to +30	°C	
36-39	Probe selections	0=off 1=on		where
47	Alarm averaging time	00:30 to 03:00	hr:mn	C = closed
48	Compressor starts/hour	unlimited /10/15/20		O = open
49	Refrigeration delay after defrost	00:00 to 00:10	hr:mn	x = don't care
50	Defrost termination temp (air off)	0 to +20	°C	
51-56	Defrost schedule	00:01 - 23:59	hr:mn	closed = dot visible
57	Defrost termination time	00:05 to 01:00	hr:mn	
58	Defrost initiation temp (suction)	-5 to +20	°C	
59	Drain down time	00:00 - 00:10	hr:mn	
60	Defrost schedule 12/24 hour clock	0=24hr 1=12hr		
61	Pump down time	00:00 - 00:10	hr:mn	
62	Network shutdown and fans only commands	0=disabled 1=enabled		
65	Invert defrost input	0=no 1=yes		
69	Number of defrosts expected	0 to 12		
75	Defrost control mode	0=termination 1=control		
102	Temperature sensor type	0=JTL(5K) 1=Elm(2K)		
106	Auxiliary output selection	0=off 1=Fan 2=Heater		
107	Defrost strategy	0=none 1=Suction 2=Network (learned backup) 3=Time 4=Contact 7=Network (real time backup)		
108	Fan control	1=run always 2=off during defrost		
109	Fan delay after defrost	00:00 to 00:10	hr:mn	
110	Lighting control selection	0=off 1=on		
118	Lighting contractor selection	0=n.o 1=n.c		
119	Enable lights shutdown from display	0=disabled 1=enabled		
122	Temperature display choice	0=celsius 1=fahrenheit		
123	Enable 2nd setpoint	0=disabled 1=enabled		
124	Primary cabinet temperature setpoint	-30 to +10	°C	
125	Secondary cabinet temperature setpoint	-30 to +10	°C	
129	Temperature display type choice	2=standard 3=enhanced		
130	Energy saving probe selection	0=off 1=on		
132	Fan control temperature setpoint	-30 to +8	°C	
133	Enable plant to override temp control	0=disabled 1=enabled		
134	Enable plant to cut off refrigeration	0=disabled 1=enabled		
136	Enable fans only mode from display	0=disabled 1=enabled		
138	Enable display controlled shutdown	0=disabled 1=enabled		
140	Temperature control deadband	0.2 to 3.0	°C	
144	Defrost termination method	1=Evaporator 2= Air off 3=Termination 4=Time only		
145	Minimum defrost time	00:00 - 00:30	hr:mn	
147	Termination sensor selection	0=Off 1=On		
200	Exclude lights shutdown from display	0=include 1=exclude		

OTHER USEFUL ITEMS			
Item	Function	Item	Function
20	Cabinet temperature	74	Auxiliary output state
21	Air on temperature	77	Forced defrost
22	Air off temperature	78	Inhibit defrost
23	Evaporator temperature	79	Forced refrigeration
24	Suction line temperature	111	Communications lighting command
28	Effective air off setpoint	112	Lighting override input state
30	Cabinet temperature setpoint	113	Lighting output state
40	Duration of last defrost	114	Force lights on
41	Time since end of last defrost	115	Force lights off
42	Duration of this defrost	131	Energy saving temperature
46	Communications defrost command	141	Termination sensor temperature
63	Network shutdown and fans only command states	203	Associated plant suction line
70	Operating mode	240	Liquid valve open %
71	Defrost input state	241	Average liquid valve open %
72	Defrost output state	261-272	Learned defrost schedule
73	Liquid valve output state		

OUTPUT STATE DIAGRAM FOR JTL CONTROLLER						LCPT	
MODE OF OPERATION	OUTPUT & FUNCTION (See note 5)						
	RL2		RL3	RL4		RL5	
	AUXILIARY (N/O) can be set to run always [108] See Note 2		TRIM HEATER (N/O)	DEFROST (C/O)		LIQUID SOLENOID VALVE (C/O)	
	ITEM 106			ITEM 75			
	Heater	Fans		CONTROL	TERMINATION		
NORMAL REFRIGERATION CYCLE	REFRIGERATION	OFF	ON (See note 3)	ON	OFF	ON ABOVE TERMINATION TEMP	CYCLES ON AIR OFF TEMPERATURE
	PUMP DOWN Adjustable time [61]	OFF	OFF	ON	OFF (from version)	OFF	OFF
	DEFROST Time/temp terminated [57]/[50]	ON	OFF	ON	CYCLES ON TERMINATION TEMP (from version)	OFF	OFF
	DRAIN DOWN Adjustable time [59]	ON	OFF	ON	OFF	ON	OFF
	LIQUID HOLD OFF Adjustable time [49]	OFF	OFF	ON	OFF	ON	OFF
	RECOVERY TIME Time/temp terminated	OFF	CYCLES ON EVAPORATOR TEMPERATURE	ON	OFF	ON	CYCLES ON AIR OFF TEMPERATURE
	REFRIGERATION	OFF	ON (See note 3)	ON	OFF	ON ABOVE TERMINATION TEMP	CYCLES ON AIR OFF TEMPERATURE
PLANT FAULT	OFF	OFF	ON	OFF	ON	OFF	
UNIT SHUTDOWN	OFF	OFF	OFF	OFF	OFF	OFF	
FANS ONLY SHUTDOWN	OFF	ON	OFF	OFF	OFF	OFF	
FORCED DEFROST	ON	ON	ON	ON	OFF	OFF	
FORCED REFRIGERATION	OFF	ON	ON	OFF	ON	CYCLES ON AIR OFF TEMPERATURE	
INHIBIT DEFROST	OFF	ON	ON	OFF	ON	CYCLES ON AIR OFF TEMPERATURE	

NOTE 2: CAN BE SET TO OFF USING ITEM 106

NOTE 3: CAN CYCLE ON ENERGY SAVING TEMPERATURE (SELECTED BY ITEM 130)

NOTE 5: RL1 IS FOR LIGHTING CONTROL

#### Relay Output Rating

5A resistive.

#### Supply Requirements

230 V ac 48-62 Hz Supply 6 VA maximum inputs 2 mA maximum

**Note** The information contained in this document applies to the current version of the unit supplied with it.



This unit conforms with the relevant EU standards when fitted in accordance with its installation instructions.