

**Electrical Installation Requirements**

Care should be taken to separate the power and signal cables to prevent electrical interference and possible damage due to inadvertent connection.

The power outputs are fitted with suppressors to protect against electrical interference when switching off solenoid valves or contactors. It is therefore essential to observe the output polarity. The line voltage should be connected to the terminals marked **LN** and the switched loads to **NO** or **NC**.

The plant inputs are electrically isolated. A line voltage should be connected for the logical conditions **lighting override** and **defrost on**. The terminals marked **C** should be connected to the supply voltage neutral.

**CE Conformance**

This unit conforms with the relevant EU standards when installed according to the JTL Installation Requirements for this product

**Inputs**

Input (CON 2)			
I1 C	INPUT 1	(LINE) (NEUTRAL)	DEFROST ON
I2 C	INPUT 2	(LINE) (NEUTRAL)	LIGHTING OVERRIDE
Temperatures and Pressure (CON 4)			
1, 2	AIR ON TEMP		
3, 4	AIR OFF 1 TEMP		
5, 6	SUCTION LINE		
7, 8	EVAPORATOR		
9, 10	ENERGY SAVING OR TERMINATION		
11, 12	AIR OFF 2 TEMP		
13, 14	AIR OFF 3 TEMP		

**Outputs**

Outputs (CON 3)			
1 NO 1 LN	OUTPUT 1	(N/O LOAD) (LINE)	LIGHTING & BLINDS CONTACTOR
2 NO 2 LN	OUTPUT 2	(N/O LOAD) (LINE)	FANS / HEATERS
3 NO 3 LN	OUTPUT 3	(N/O LOAD) (LINE)	TRIM HEATER
4 NO 4 LN 4 NC	OUTPUT 4	(N/O LOAD) (LINE) (N/C LOAD)	DEFROST
5 NO 5 LN 5 NC	OUTPUT 5	(N/O LOAD) (LINE) N/C LOAD	LIQUID SOLENOID VALVE

**Use of Maintenance Unit**

The controller can be checked and the operation adjusted using a JTL portable maintenance unit which plugs into the controller. Each item of information has an item number. The more important items are listed in the tables overleaf.

Examples:  
To read item 21 press: **ITEM** **2** **1** **ENTER**

To set item 30 to -20.0 press:  
**ITEM** **3** **0** **ENTER** **SET** **-** **2** **0** **0** **ENTER**

To correct errors press: **CANCEL**

To select next or previous items press: **+** and **-**

**Initial Commissioning and Bitswitch Settings**

The controller has 4 sets of data built in to its program for use during commissioning. These can be accessed by setting the bitswitches as shown in the table overleaf and then setting item 9 to 1234. From v0.01.1 this controller has virtual bitswitches which replace the physical bitswitches. The virtual bitswitches are set using item 966. This loads into the controller a suitable set of data for the selected type of case. Adjustments should then be made as necessary. The range over which the settings can be adjusted is also defined by the bitswitch setting.

If a JTL communications network is connected to the controller then the unit number should be set on item 1.

**Temperature Display**

The temperature displayed is computed from the air on and air off temperatures. A factor is used to proportion the air off and air on temperatures. The temperature can be displayed in Celsius or Fahrenheit as selected by item 122.

The LAPN controller will drive the following JTL displays when used with the CAB55 extension cable.

Display	Cable	Switch
LCD8	CAB55	None
LCD9	CAB55	3 position
LCD11	CAB55	4 position

The LCD9 and LCD11 displays incorporate a keyswitch. This switch can be used to select various functions as described below. A maximum of 2 additional functions can be selected. On LCD9 if only one additional function is selected, then it is available in either of the extra 2 positions.

The CAB55 cable is available in various lengths.

**Air off Temperature**

The LAPN controller supports up to 3 air off temperature sensors, each of which is individually selected using item 37 (408). The air off temperature is calculated from these 3 sensors on the basis of highest, middle, lowest or average. The calculation method is selected on item 408. Any combination of 1, 2 or 3 air off sensors is permitted. In the event of a sensor fault, the faulty sensor is automatically discarded from the calculation.

**Control Strategy**

The controller can control to the cabinet temperature or the air off temperature as selected using item 275. The air off temperature is controlled to a computed setpoint shown on item 28, by controlling a liquid line solenoid valve with a mechanical expansion valve.

The computed air off temperature setpoint is calculated by comparing the displayed temperature with the cabinet temperature setpoint. The computed setpoint is raised or lowered depending on whether the cabinet temperature is below or above the cabinet temperature setpoint. The computed air off setpoint cannot go below the value set on item 31.

The LAPN controller can be set to operate from 2 cabinet temperature setpoints by setting item 123. The setpoint to be used is then selected using the display keyswitch. The setpoints are set on items 124 and 125 and the current setpoint is displayed on item 30.

For liquid solenoid control, if the air off temperature falls below the computed setpoint the liquid valve is closed. There is an adjustable deadband set using item 140.

**Defrost Initiation Strategies**

The defrost strategy can be initiated in 4 fundamental ways using item 107. Defrost initiation can be by real time clock, by deduction from the suction temperature, by command on the JTL communications network, or by contact input.

Network initiated defrost can be divided into 3 groups; PREDICT, coordinated and scheduled.

PREDICT defrost requires that a JTL PREDICT defrost coordinator unit is available on the network. This unit receives requests from the PREDICT controllers and coordinates these requests so that the defrosts are organised ensuring the electrical and refrigeration requirements are met. When the controller requests a defrost the PREDICT coordinator will send out a defrost command at a suitable time. If the backup strategy is invoked the controller reverts to real time schedule.

Coordinated timed defrost requires a timed defrost or defrost coordinator to be present in the network. When coordinated timed request is selected then the controller requests a defrost as defined by the number of defrosts a day as set on item 69. The defrost coordinator coordinates the defrost as required. The backup strategy can be chosen to fall to learned defrost schedule or real time backup.

**NOTE:** No suction initiated defrost can be detected within 3 hours of the previous defrost.

**Backup Defrost Initiation Strategies**

For network initiated defrost, 2 defrost backup strategies are included. The strategy choice is made on item 107.

For learned backup the last 24 hours defrost operation is continuously monitored and the defrost schedule is learned. For real time backup the defrost schedule as set up for real time defrost on items 51-56 is used.

If network communication fails, the selected backup strategy is automatically used. The unit reverts to network control whenever the network communications is operational.

The backup strategy is also invoked if the network signals that communications has failed to the defrost scheduler or if there is a fault at the defrost scheduler.

**Defrost**

There is a choice of 2 methods of defrost operation, termination or control, using item 75. In termination mode the defrost output relay is energised during defrost recovery period and at any time when the termination temperature is exceeded. In control mode the defrost output relay is energised during the defrost period.

The liquid solenoid is closed during all forms of defrost. The auxiliary output can be selected for fan or heater control. During defrost the fans can be stopped or the auxiliary heater energised.

For network, real time and contact initiated defrost a pump down delay can be applied (item 61) before the defrost/output and heater are energised. During pump down the liquid outputs are deenergised.

The display shows "dEF "

**Defrost Termination**

The controller stays in defrost at least until the minimum defrost time, on item 145, is exceeded. If the termination temperature is reached before the minimum defrost time then the defrost heater is cycled.

**Defrost Recovery**

When the termination temperature or time is reached the controller enters defrost recovery. The heater is de-energised. The termination method can be chosen using item 144.

For network, real time and contact initiated defrost a time delay can be applied (item 49) after defrost before the liquid valve is reopened.

A drain down time delay can be applied (item 59) after defrost before the liquid valve is reopened. During drain down if the auxiliary heater output is selected it is energised.

The display shows "dEFr".

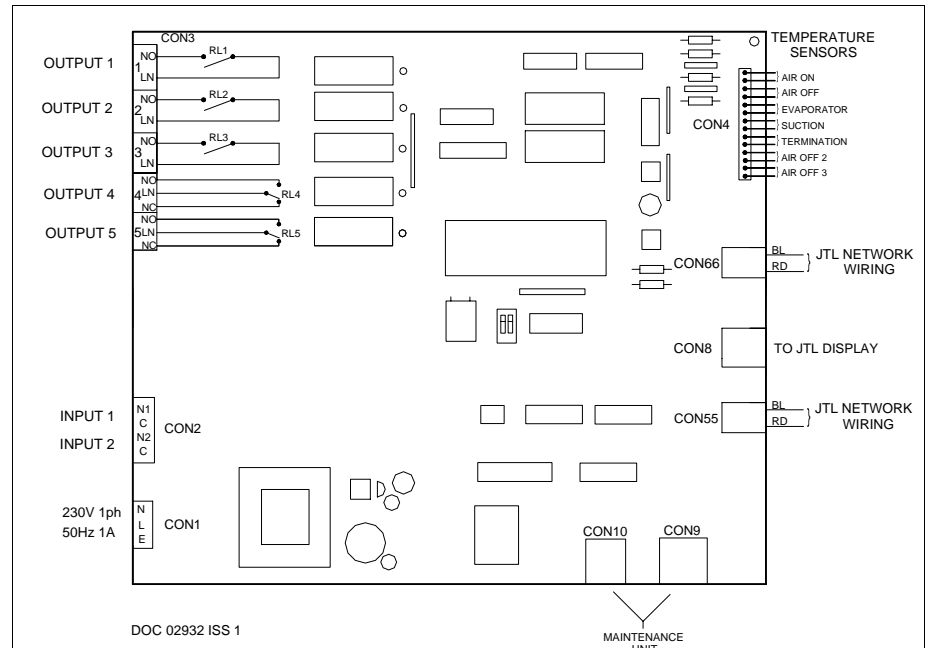

**Forced Refrigeration and Defrost**

The maintenance unit can be used to force controller into a particular mode. This is done using items 77-79. While the maintenance unit is plugged in the controller will remain in the selected mode permanently. Once the maintenance unit is unplugged the controller will revert to normal control after 30 minutes.

When the network initiated defrost strategy is selected, forced defrost will send a command to the JTL defrost scheduler to initiate a defrost and does not act locally.

**Fan Control**

The fans can be controlled in various ways.

If item 108 is set to "fans off during defrost" then during defrost recovery the fans can be controlled depending on the evaporator temperature or time delay after defrost. If item 109 is set to 00:00 when the evaporator temperature is low enough, the fans start. There is a 5 degree deadband. If item 109 is set to a time then the fans are held off until the time delay has occurred.

If item 108 is set to "fan control during defrost"; the fans are turned off during defrost when the evaporating temperature goes above the setting on item 146. After defrost the fans are turned on when the evaporating temperature falls below the setting on item 150 or the time delay on item 109, if it is not set to 00:00.

If energy saving is selected using item 130, then the fans will be cycled during normal refrigeration. When the energy saving temperature, item 131, goes below the energy saving setpoint, item 132, the fans stop. There is a deadband of ±0.5°C

**Trim heater control**

The trim heaters can be controlled. There are 4 separate strategies for control selected by item 390.

- a) heater switched off when controller shutdown using display keyswitch.
  - b) heater controlled to a fixed percentage output
  - c) heater controlled to a fixed percentage output which can vary in and out of trading hours.
  - d) heater controlled with an adjustment received from the network.
- The trim heater control is achieved by pulsing relay RL3. The pulse period in 400 seconds. For example to achieve 75% output the heater is on for 300 s and off for 100s. The percentage can be set for day operation (item 392), for night setback (item 393), and adjusted further by a network command from a trim heater optimiser on the JTL network (item 394). The current percentage in operation is displayed on item 391.

**Lighting and Night Blind Control**

The cabinet lights and night blinds can be sequenced on and off by command from the JTL network. An override switch input facility is provided which raises the blinds and turns the lights on. The lights can be switched off from the display keyswitch if item 119 is set to 1 (enabled). The lights are switched off if either fans only or shutdown are selected.

**High Temperature Alarms**

The cabinet and air off temperatures are monitored continually. The temperatures are averaged over the period set on item 47. If either of the average temperatures exceeds the alarm level then an alarm is given which is shown on the display and available, for remote indication, on the JTL alarm system. High temperature alarms are cancelled during defrost and defrost recovery.

The cabinet temperature tolerance is set on item 32 and the air off tolerance on item 34. Setting either of these tolerances to 0.0°C disables the relevant alarm.

**Network Shutdown and Fans Only Mode**

This controller supports the JTL Network shutdown and fans only facilities. When these facilities are enabled by item 62. If a shutdown or fans only command is received over the JTL Network, the refrigeration is stopped and alarms are disabled. The high temperature alarm sequence is initialised.

**Display Controlled Shutdown**

The controller can be shutdown for servicing purposes using the display switch. This feature is enabled by item 138.

**Display Controlled Fans Only Mode**

The controller can be put into fans only mode using the display switch. This feature is enabled by item 136.

**Suction Pressure Optimisation**

When used in conjunction with JTL pack control and suction optimisers this unit is normally included in the suction pressure optimiser algorithm. It can be explicitly excluded by setting item 200 to 1.

**Daylight Saving**

When connected to a JTL network this controller can operate by displaying daylight saving time for its time and defrost schedule. Daylight saving operation is selected by setting item 18. The connected network controller then adjusts the times automatically during the daylight saving period.

ADJUSTABLE PARAMETERS				LAPN
	item	Function	Range	Units
TEMPS & ALARMS	33	Cabinet temperature ratio	20 to 80	hr:mn
	408	Air off calculation method	1=Lowest 2=Middle 3=Highest 4=Average 5=Average lowest 2 6=Average highest 2	
	36-39	Sensor selections	0=off 1=on	
	147	Termination sensor selection	0=off 1=on	
	32	Cabinet overtemperature tolerance	0 to +20	°C
	34	Air off over temperature tolerance	0 to +30	°C
	47	Alarm averaging time	00:30 to 03:00	hr:mn
CONTROL	275	Control temperature	1= Air off 2= Cabinet temp	°C
	123	Enable 2nd setpoint	0=disabled 1=enabled	°C
	124	Primary cabinet temperature setpoint	-30 to +10	°C
	125	Secondary cabinet temperature setpoint	-30 to +10	°C
	31	Air off temperature setpoint	-39 to +5	°C
	140	Temperature control deadband	0.4 to 3.0	
	48	Compressor starts/hour	unlimited /10/15/20	
	75	Defrost control mode	0=termination 1=control	
	106	Auxiliary output selection	0=off 1=Fan 2=Heater	
DEFROST INITIATION	107	Defrost strategy	0=none 1=Suction 2=Network (learned backup)3=Time 4=Contact 5=PREDICT 7=Network (real time backup) 8=Coordinated (learned) 9=Coordinated (real time)	hr:mn
	69	Number of defrosts expected or required	0 to 12	hr:mn
	61	Pump down time	00:00 - 00:10	hr:mn
	51-56	Defrost schedule	00:01 - 23:59	°C
	60	Defrost schedule 12/24 hour clock	0=24hr 1=12hr	
	58	Defrost initiation temp (suction)	-5 to +20	
	65	Invert defrost input	0=no 1=yes	
	211	Evaporator group	0=none 1=Lt 2=Ht 3=Satellite	
	210	Electrical supply distribution panel no	0 to 15=panel no	
	213	Electrical supply circuit	0=none 1-15=circuit	
	214	Defrost method	0=brown phase 1=black phase 2=grey phase 3=3 phase 4=2 pipe gas 5=3 pipe gas 6=off cycle	
	223	Defrost requirement priority	1 to 8	hours
	225	PREDICT Minimum time between defrosts	2 to 8	hours
	226	PREDICT Maximum time between defrosts	6 to 72	
227	PREDICT Sample discard list	0 to 3		
228	PREDICT volatility setpoint	2 to 12		
DEFROST TERMINATION	144	Defrost termination method	1=Evaporator 2= Air off 3=Termination 4=Time only	°C
	50	Defrost termination temp	0 to +20	hr:mn
	145	Minimum defrost time	00:00 - 00:30	hr:mn
	57	Defrost termination time	00:05 to 00:59	hr:mn
	59	Drain down time	00:00 to 00:10	hr:mn
	49	Refrigeration delay after defrost	00:00 to 00:10	hr:mn
FAN CONTROL	108	Fan control	1=run always 2=off during defrost 3=fan controlled during defrost	°C
	146	Temperature to turn fans off during defrost	-12 to +20	hr:mn
	109	Fan delay after defrost	00:00 - 00:10	°C
	150	Temperature to turn fans on after defrost	-20 to +5	
	130	Fan control sensor selection	0=disabled 1=enabled	
	132	Fan control temperature setpoint	-30 to +8	°C
TRIM HEATER CONTROL	390	Control strategy	1 =off, 2=off when shutdown, 3 =fixed adjustment, 4= night setback, 5= network control	%
	392	Normal percentage operation		%
	393	Night setback operation		%
LIGHTING CONTROL	110	Jnet lighting control selection	0=disabled 1=enabled	
	118	Lighting contractor selection	0=n.o 1=n.c	
	119	Enable lights during shutdown	0=disabled 1=enabled	
Jnet FUNCTIONS	1	Unit number	0.1 - 899.8	
	62	Jnet network shutdown selection	0=disabled 1=enabled	
	133	Enable plant to override temp control	0=off 1=on	
	134	Enable plant to cut off refrigeration	0=disabled 1=enabled	
	18	Daylight saving operation	0=standard time 1=daylight saving time	
DISPLAY	122	Temperature display choice	0=celsius 1=fahrenheit	
	136	Enable fans only mode from display	0=disabled 1=enabled	
	138	Enable display controlled shutdown	0=Off 1=On	

Bitswitch settings 21, 0(C) Frozen food, 1 (CO) Ice cream, 2 (CO) Chillers, 3(OO) Produce, where C = closed, O = open, closed = dot visible (0 to 3 is the virtual bitswitch setting on item 966)

OTHER USEFUL ITEMS					
Item	Function	Item	Function	Item	Function
20	<b>TEMPERATURES</b>	70	<b>MODE INPUTS &amp; OUTPUTS</b>	40	<b>DEFROST</b>
21	Cabinet temperature	71	Operating mode	41	Duration of last defrost
22	Air on temperature	72	Defrost input state	42	Time since end of last defrost
23	Air off temperature	73	Defrost output state	46	Duration of this defrost
24	Evaporator temperature	74	Liquid valve output state	47	Communications defrost command
401	Suction line temperature	395	Auxiliary output state	77	Forced defrost
402	Air off 1 temperature	391	Trim heater state	78	Inhibit defrost
403	Air off 2 temperature		Trim heater %	79	Forced refrigeration
131	Air off 3 temperature	111	<b>LIGHTING</b>	261-272	Learned defrost schedule
141	Energy saving temperature	112	Communications lighting command	219	Defrost arrangement from network
	Termination sensor temperature	113	Lighting override input state	221	Forced defrost requirement
30	<b>CONTROL</b>	114	Lighting output state	222	Enable forced defrost requirement
28	Cabinet temperature setpoint	115	Force lights on		<b>Jnet NETWORK FUNCTIONS</b>
240	Effective air off setpoint		Force lights off	63	Network shutdown and fans only command states
241	Liquid valve open %			203	Associated plant suction line
	Average liquid valve open %			394	Trim heater adjustment

OUTPUT STATE DIAGRAM FOR JTL CONTROLLER						LAPN
MODE OF OPERATION	OUTPUT & FUNCTION (See note 5)					
	RL2		RL3	RL4		RL5
	AUXILIARY (N/O)		TRIM HEATER (N/O) (Strategy on item 390)	DEFROST (C/O)		LIQUID SOLENOID VALVE (C/O)
	ITEM 106			ITEM 75		
	Heater	Fans	CONTROL	TERMINATION		
<b>REFRIGERATION</b>	OFF	ON (See note 3)	ON	OFF	ON ABOVE TERMINATION TEMP	CYCLES ON AIR OFF TEMPERATURE
<b>PUMP DOWN</b> Adjustable time (61)	OFF	ON/OFF (See note 2)	ON	OFF	OFF	OFF
<b>DEFROST</b> Time/temp terminated (57)/(50)	ON	ON/OFF (See note 2)	ON	CYCLES ON TERMINATION TEMP	OFF	OFF
<b>DRAIN DOWN</b> Adjustable time (59)	ON	ON/OFF (See note 2)	ON	OFF	ON	OFF
<b>LIQUID HOLD OFF</b> Adjustable time (49)	OFF	ON/OFF (See note 2)	ON	OFF	ON	OFF
<b>RECOVERY TIME</b> Time/temp terminated	OFF	ON/OFF CYCLES ON EVAPORATOR TEMPERATURE (See note 2)	ON	OFF	ON	CYCLES ON AIR OFF TEMPERATURE
<b>REFRIGERATION</b>	OFF	ON (See note 3)	ON	OFF	ON ABOVE TERMINATION TEMP	CYCLES ON AIR OFF TEMPERATURE
<b>PLANT FAULT</b>	OFF	OFF	ON	OFF	ON	OFF
<b>UNIT SHUTDOWN</b>	OFF	OFF	OFF	OFF	OFF	OFF
<b>FANS ONLY SHUTDOWN</b>	OFF	ON	OFF	OFF	OFF	OFF
<b>FORCED DEFROST</b>	ON	ON	ON	ON	OFF	OFF
<b>FORCED REFRIGERATION</b>	OFF	ON	ON	OFF	ON	ON
<b>INHIBIT DEFROST</b>	OFF	ON	ON	OFF	ON	CYCLES ON AIR OFF TEMPERATURE

NOTE 2: FAN CONTROL ON OFF OR CYCLED, DEPENDING ON ITEM 108 SETTING ON EVAPORATOR TEMPERATURE

NOTE 3: CAN CYCLE ON ENERGY SAVING TEMPERATURE (SELECTED BY ITEM 130)

NOTE 5: RL1 IS FOR LIGHTING CONTROL

#### Relay Output Rating

5A resistive.

#### Supply Requirements

230 V ac 48-62 Hz Supply 6 VA maximum inputs 2 mA maximum



This unit conforms with the relevant EU standards when fitted in accordance with its installation instructions.

#### Note

The information contained in this document applies to the current version of the unit supplied with it. Full operating manuals, item number and software variation information can be obtained from your supplier or JTL Systems. Technical documentation can also be obtained from our website www.jtl.co.uk.

#### Applicable Documentation

Item Numbers	Firmware Variations	Connections Diagram	Schematic Diagram
Doc No. 02774	Doc No. 02775	Doc No. 02877	02876

#### Evaporator Manual

Doc No. 01923

#### Installation Information

Doc No. 03036