

Electrical Installation Requirements

Care should be taken to separate the power and signal cables to prevent electrical interference and possible damage due to inadvertent connection.

The inputs are electrically isolated for use with voltage free contacts.

In order for inbuilt suppressors to function the outputs MUST be wired according to the application drawings.

CE Conformance

This unit conforms with the relevant EU standards when installed according to the JTL Installation Requirements for this product.

Description

JTL IF6x type interfaces are designed to be used with a JTL plant controller. This interface comprises four optically isolated mains "digital" inputs, four suppressed non-changeover relay outputs, two 0-10V analogue outputs, and four 5k temperature sensor (TP501) inputs. A JTL maintenance unit is required to configure this product.

Use of Maintenance Unit

The interface can be checked and the operation adjusted using a JTL portable maintenance unit which plugs into the interface. Each item of information has an item number. The more important items are listed in the tables overleaf. Examples:

To read item 30 press: **ITEM** **3** **0** **ENTER**

To set item 31 to 2 press: **ITEM** **3** **1** **ENTER** **SET** **2** **ENTER**

To correct errors press: **CANCEL**

To select next or previous items press: **-** and **+**

JTL Network Communications

The JTL network port is arranged for 2 wire (half duplex) communications.

Connections to the Interface plant zone use JTL cables type CAB60. Communications speed should be set to 9600 baud setting item 36=4. The plant controller should be set to 9600 baud also.

Configuration & Communications Protocol

Item 37 = b.ASC(0) or b.rtu(3) (Modbus ASCII or Modbus RTU)

For use with JTL controllers using Modbus protocols.

Item 37 = b.PL.1 (1) or J.PL.2 (2) (JTL Plant Protocol)

In non modbus mode the interface behaves as two separate, individually addressable, analogue interfaces or channels.

Each channel has a 0-10V analogue output two relays and two self energising digital inputs associated with it. Both channels are enabled when Item37 = 2, or just Channel 1 when Item 37 = 1.

The analogue output is directly controlled by the plant controller, and the state two of digital inputs is passed back to the plant controller.

The primary relay for each channel is energised if the analogue command from the plant controller is non-zero and conversely de-energised when the command is zero.

The secondary relay is energised if the analogue command from the plant controller exceeds a switch-on threshold (item 39 or 49) and de-energised when the command equals or falls below the switch-off threshold (item 38 or 48). Threshold values are set as a percentage of full scale analogue output.

	Ch1	Ch2
Primary	DQ1	DQ3
Secondary	DQ2	DQ4
Input 1	DI1	DI3
Input 2	DI2	DI4
Analogue output	AQ1	AQ2

Backup

Backup mode behaves differently depending on the chosen communication protocol. Backup mode is activated in all cases if there is no communication from the main controller for approximately 90 seconds. Until this time the interface holds the state of its outputs as last set.

Modbus Mode

In Modbus protocols when backup mode is entered the preset backup values (0-100%) for the analogue outputs (item 32-CH1, Item 33-CH2) are set on the respective output channels. Relay output states in backup are set on Item 35 in binary code. For example 0 = all relays de-energised, and 15= all relays energised. See section on Binary Codes for Inputs and Outputs later in this document.

JTL Plant Zone Protocol

Owing to the more simple nature of the legacy JTL plant zone protocol relay outputs are controlled in backup mode according to the corresponding channel analogue backup value. Zero means both relays off, non zero means both relays energised, regardless of the on/off threshold settings.

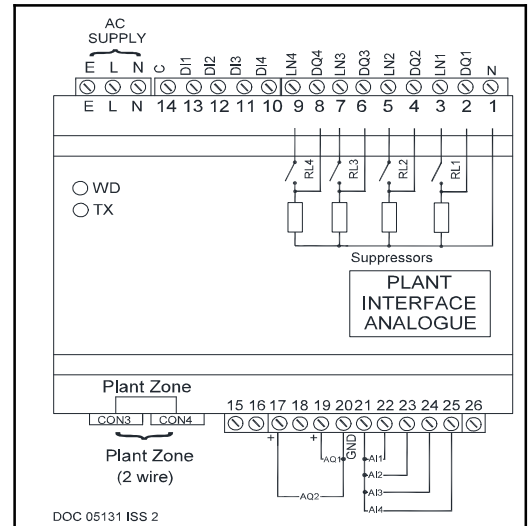

Maintenance Features

In addition to address configuration, the maintenance unit enables the user to look at various items for diagnostic purposes.

Logical inputs (the inputs the plant controller sees) are displayed on item 71 in binary coded form. These input values can be forced to read differently by setting a non-zero value on item 78. The physical inputs however, are always displayed on item 100.

Logical outputs (outputs commanded by the plant controller) are displayed in binary coded form on item 72. Physical relay outputs are displayed on item 73.

Physical outputs can be forced, overriding plant controller commands by entering a non zero value in item 79.

Forced functions remain forced whilst the maintenance unit is plugged in. They are cancelled automatically 30 minutes after the maintenance unit is unplugged.

Two LEDs are located in the top left hand corner of the unit. These are for diagnostic purposes.

WD (Green) = Watchdog, blinks if board is healthy

TX (Red) = Illuminated when interface is transmitting data to pack controller

Binary Codes for Inputs & Outputs

When forcng input or output (eg item 78 & 79) items in the maintenance unit the binary coding works as follows:

- 1 = input 1 / output 1
- 2 = input 2 / output 2
- 4 = input 3 / output 3
- 8 = input 4 / output 4

The inputs and outputs are shown as segment pateerns on status items.

ADJUSTABLE PARAMETERS		
Item	Function	Range
30	Primary Interface number (channel 1)/ Modbus device address	0 - 9/1 - 254
31*	Primary Interface type (channel 1)	0 - 15
40*	Secondary interface number (channel 2)	0 - 9
41*	Secondary interface type (channel 2)	0 - 15
34*	Max steps for 100% outputs	99 to 127
36	Communications baud rate	1=1200 2=2400 3=4800 4=9600 5=19200
37	Communications protocol	0=Modbus ASCII 1=JTL single channel 2=JTL dual channel 3=Modbus RTU (v1.00.4 on)
32	Backup value (channel 1)	0 - 100%
33	Backup value (channel 2)	0 - 100%
35	Backup condition for relay outputs **	0 - 15 binary code for relays 1-4
38*	Ch1 Secondary relay switch off threshold	0 - 100% of full analogue output
39*	Ch1 Secondary relay switch on threshold	0 - 100% of full analogue output
48*	Ch2 Secondary relay switch off threshold	0 - 100% of full analogue output
49*	Ch2 Secondary relay switch on threshold	0 - 100% of full analogue output

* Applicable to JTL Plant Zone Protocol only

** Applicable Modbus Protocol only

OTHER USEFUL ITEMS	
Item	Function
21	Channel 1 RAW ADC reading
22	Channel 2 RAW ADC reading
23	Channel 3 RAW ADC reading
24	Channel 4 RAW ADC reading
111	Channel 1 temperature
121	Channel 2 temperature
131	Channel 3 temperature
141	Channel 4 temperature
51	Channel 1 DAC (0 - 4095)
52	Channel 2 DAC (0 - 4095)
71	Logical input status (as seen by main controller)
72	Logical relay output status (as sent by main controller)
73	Relay output status (actual)
78	Forced input status (for maintenance purposes)
79	Forced relay output status (for maintenance purposes)
100	Input status (actual)

Supply Requirements and Input/Output Specification

100 - 240 Vac 50-60 Hz 0.2 A max
Relay rating 2 A resistive
0-10 V source 30 mA max

Full operating manuals and item number information can be obtained from your supplier or JTL Systems.

Technical documentation can also be obtained from our website www.jtl.co.uk.

 This unit conforms with the relevant EU standards when fitted in accordance with its installation instructions.

Applicable Documentation

Item Numbers	Doc No. 05127
Firmware Variations	Doc No. 05128
Connections Diagram	Doc No. 05129
Installation Requirements	Doc No. 02777

Application Drawing

Doc No. 05095